



# The FINGER ENGINE

BY T PARKINSON

Several years ago, the North American Model Engineering Society featured a simple horizontal finger engine as a project, complete with plans in their event program. A finger engine is simple, and it is an excellent and meaningful project to be done with a youngster(s).

The 2005 NAMES Vertical Finger Engine features a hardwood base, aluminum, brass and steel parts, and a cast flywheel. Flywheel castings are available from several NAMES vendors.

Are fancy machine tools needed to make this fun Coffee Table curiosity? Absolutely not! If a machined flywheel is used, all the rest can be done with a wood saw, hacksaw, hand drill, center punch, file, vise, taps, drills, and countersink. In this case, the shoulder screws can be drilled brass for tube lengths, with a washer and a No. 8 screw to make up the equivalent.

A drill press will make the job easier keeping the drilled holes normal to the stock. A minimal lathe can make the shoulder screws and finish the flywheel casting.

Is any dimension particularly critical? Only a few are. These are mainly hole diameters for the shaft and the shoulder screws. The connecting rod length will determine the extreme clearances under the finger lever.

A note on that clearance: If a finger gets caught under the lever with the flywheel spinning, it will "bite."

In addition to the fun of making it, a youngster can learn the several lessons of crank machines – phasing of the finger to keep it spinning "on center," single-acting operation, double-acting operation, and the ultimate phasing of the finger pushing – reverse the direction of rotation.

Photos and drawings by Author



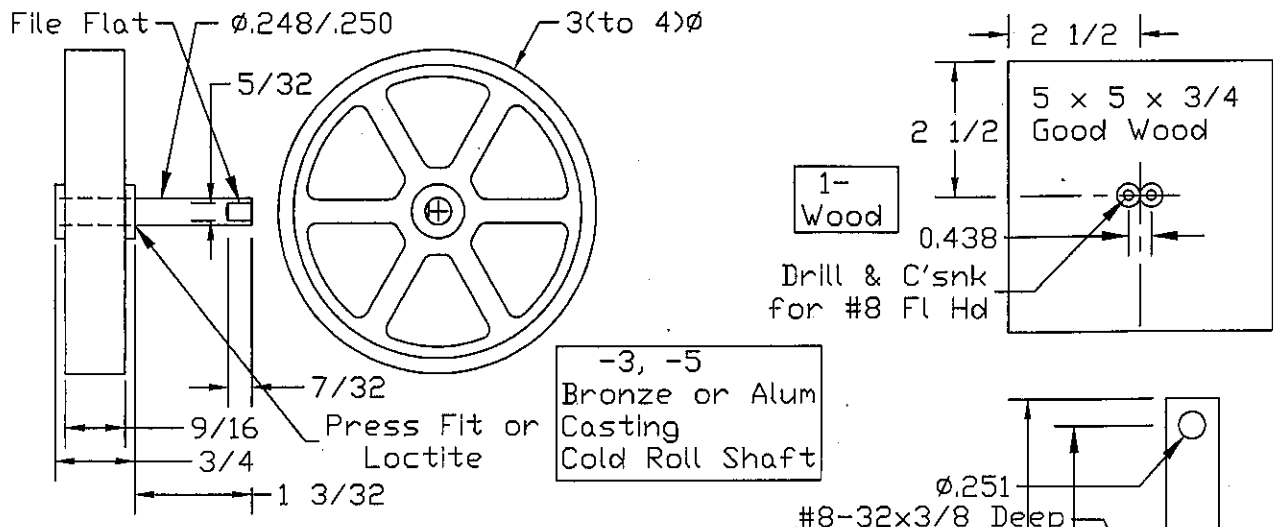

-3, -5  
Bronze or Alum  
Casting  
Cold Roll Shaft

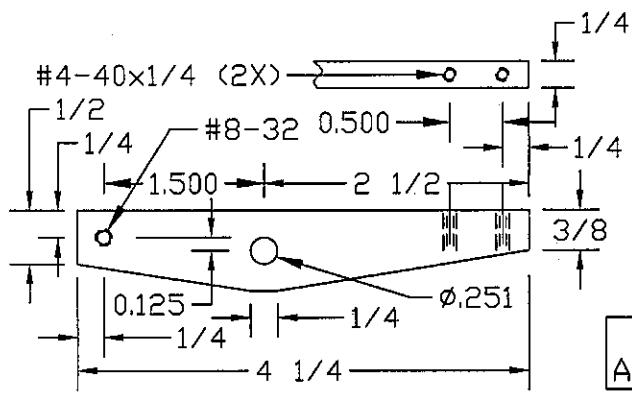

-8  
Alum

Drill & C'snk  
for #4 Fl Hd

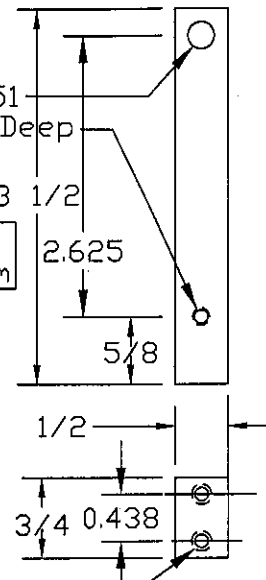

-2  
Alum

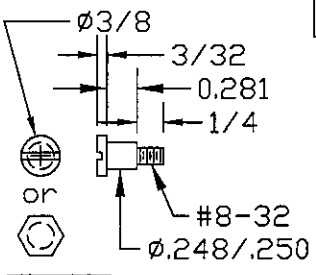

-7  
Alum

Use #8 Brass  
Washer Under Each  
Shoulder Screw, 2  
#14 Brass Washers  
on Shaft

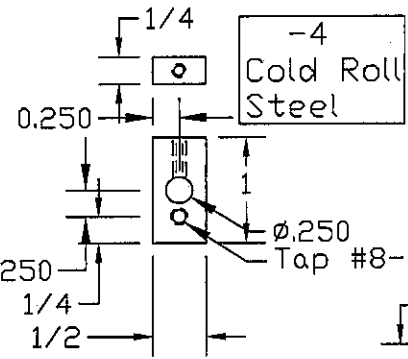

-4  
Cold Roll  
Steel

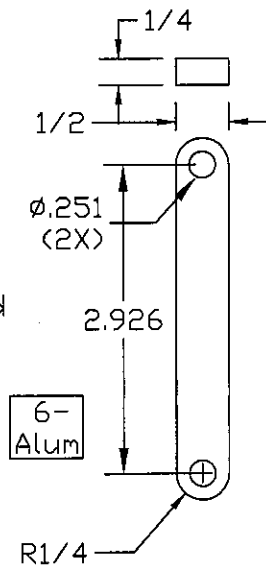
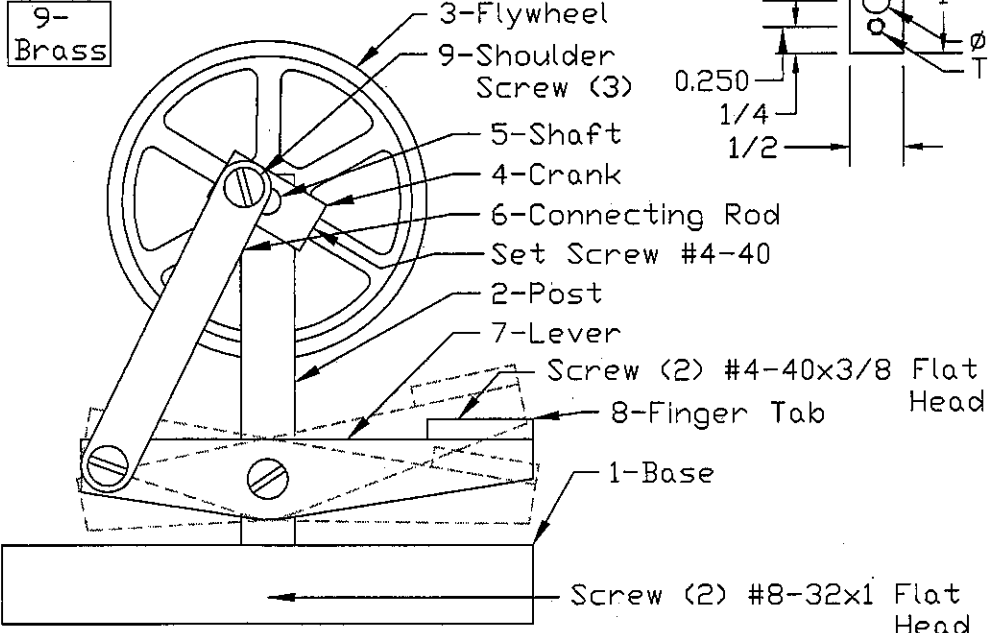

-6  
Alum

NAMES Vertical Finger Engine TDP 2/2005